



CNG System Configurations

Heil Alternative Fuel Vehicle Product Specifications

System Configurations									
		Behind the Cab	Front of Body		Roof Transverse		Roof Longitudinal		Frame Rail
		C75	B60	B75	RT60	RT75	RL60	RL75	FR80
Tanks									
Quantity		5	4	5	4	5	4	4 +1	2
Diameter	inches	16	19	16	16	16	13	13 & 24	25
Length	inches	81	81	81	81	81	120	120 & 39	80
Diesel Gallon Equivalent (DGE) capacity per tank	gallons	15	15	15	15	15	15	15 & 14.4	40
Diesel Gallon Equivalent (DGE) capacity	gallons	75	60	75	60	75	60	74.4	80

System (Pod + Fuel Management Module)									
Weight empty	pounds	1690	1110	1265	1090	1290	1500	1650	1240
Weight full	pounds	2170	1495	1750	1475	1770	1885	2115	1750
Estimated increase to overall height (OAH)	inches	—	—	—	12-20	12-20	8-14	8-14	0
Estimated increase to wheel base (WB)	inches	18-24	18-24	18-24	—	—	—	—	0-70

Availability									
Body Style	Body Size (yd ³)						✓	✓	✓
Half/Pack®, Half/Pack Sierra, and Half/Pack Freedom™ front loaders	28 & 32						✓	✓	✓
PowerTrak® and DuraPack® rear loaders	18-32		✓	✓	✓	✓			
DuraPack, Rapid Rail®, and MultiTask™ automated side loaders	16-33				✓	✓			
STARR® System	33	✓							
DualLift™, KwikLift™, and LowLift™ roll-off hoists									✓

Note: Check with your chassis provider to determine the weight reduction with a CNG chassis compared to a diesel chassis.

All designs, specifications, and components are subject to change at the manufacturer's sole discretion at any time without notice. Data published herein is for information purposes only and shall not be construed to warrant suitability of the unit for any particular purpose, as performance may vary with the conditions encountered. The only warranty is our standard written Warranty Statement for this product at the time of shipment.



2030 Hamilton Place Blvd., Suite 200, Chattanooga, TN 37421
 866.FOR.HEIL (866.367.4345) • Fax: 423.855.3478
 www.heil.com

© 2012, Heil Environmental, Printed in the U.S.A.
 FORM #SWS-000065-082912

CONTACT YOUR LOCAL DEALER



Alternative Fuel Vehicles

Compressed Natural Gas (CNG)



Compressed Natural Gas (CNG)

Heil simplifies the move to alternative fuels.

Making the move to using compressed natural gas (CNG) for your refuse vehicles is a big commitment, but it doesn't have to be a risky one. Achieving your economic and environmental objectives will depend on choosing the right partners – companies whom you can count on, both now and for years to come, as you transition your fleet to 100% CNG.

At Heil, we recognize that a CNG fuel delivery system must integrate seamlessly not only with the chassis and the body, but also your dedicated CNG fueling station, enabling your CNG-fueled unit to deliver the same productivity you would expect from a diesel unit, while saving you money with clean, domestic, compressed natural gas as fuel. Whether you are in the early stages of evaluation, or ready to make the leap forward, Heil's experts are ready to provide the guidance you need to make the right decision for your business.

Robust standard offering.

No one in the waste industry offers the breadth of CNG system configurations available from Heil. Whether your application requires a pod location on the roof, on the front of the body, behind the chassis, or on the frame rail, Heil has right design for you.

In-house manufacturing.

All our CNG systems are designed and built in-house at our Fort Payne, AL facility for seamless integration with the body and chassis you select. We also have a dedicated CNG fueling station at the facility, which enables your new Heil CNG refuse collection vehicle to be driven directly to your location when intermediate fueling stations are available en route, minimizing shipping costs and delivery lead time.

Trusted partnerships.

Heil manufactures and designs the world's best refuse collection bodies and roll-off hoists. Agility Fuel Systems has built a reputation for designing and manufacturing the world's best CNG and LNG fuel delivery systems. By partnering with Agility, we are able to bring the latest and most innovative CNG technology to our production processes and offer our customers the world's best fully integrated CNG systems.

Local service, training, and support.

Just because someone can sell you a CNG system doesn't mean they can support you properly after the purchase. Our knowledgeable and experienced nationwide Dealer network is available for you, for the entire life of your CNG system.



To view and download full product specifications on these models, visit www.heil.com.

CNG System Configuration

Compressed natural gas requires six times more storage volume than diesel fuel, so choosing the right storage capacity and system configuration is important. Whether you are concerned about the overall height of your vehicle, wheelbase and turning radius, or weight distribution, Heil will help you choose the best configuration for your application.

Five key configurations are available based on the mounting location they require and the diesel gallon equivalent (DGE) offered.

Frame Rail

Front Loaders and Roll-Off Hoists

In this configuration, two 25-inch diameter by 80-inch long 40 DGE tanks are mounted, one on each frame rail, to provide a total capacity of 80 DGE. Availability of this option depends upon the specific chassis and body options you choose.

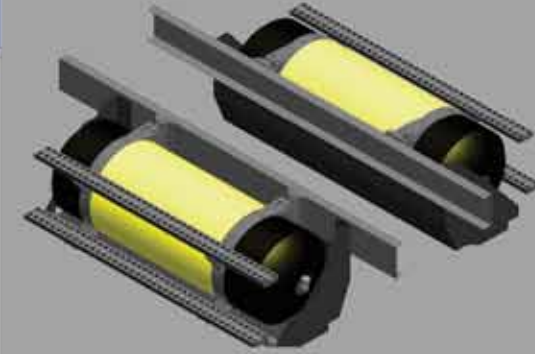

Roof Transverse

Rear Loaders and Automated Side Loaders

The roof transverse configuration is similar to the Front of Body design, except that the pod is bolted to brackets which are welded to the top of the body. The wheelbase (WB) remains the same as for a diesel unit, but the overall height is increased by 12-20 inches.

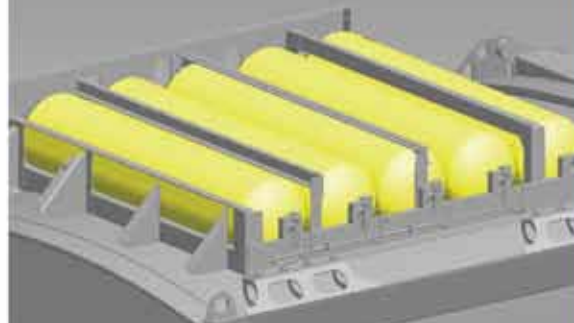

Roof Longitudinal

Front Loaders

To ensure an OAH that does not exceed 13 feet, 6 inches on a front load collection vehicle with a top door (and a chassis frame rail height less than 43 inches), this configuration uses four 13-inch diameter by 120-inch long tanks, running lengthwise on the top of the body and providing 59 DGE. An additional tank can be added on the frame rail to achieve 73 DGE.

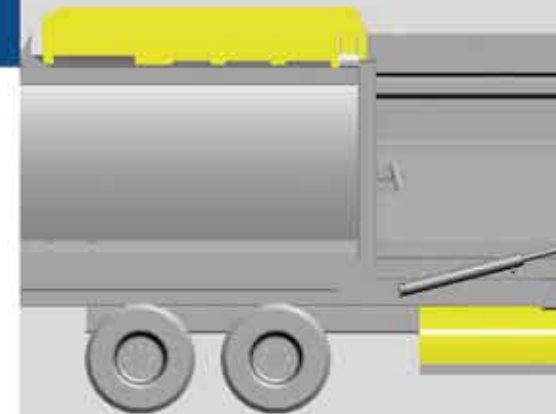

Front of Body

Rear Loaders

In this configuration, the pod contains either four or five 16-inch diameter tanks. Each tank is 15 DGE, giving a total capacity of 60 or 75 DGE. The pod is bolted to brackets which are welded to the front of the body. This design does not increase overall height (OAH), but does require an increased wheelbase WB of 18-24 inches.

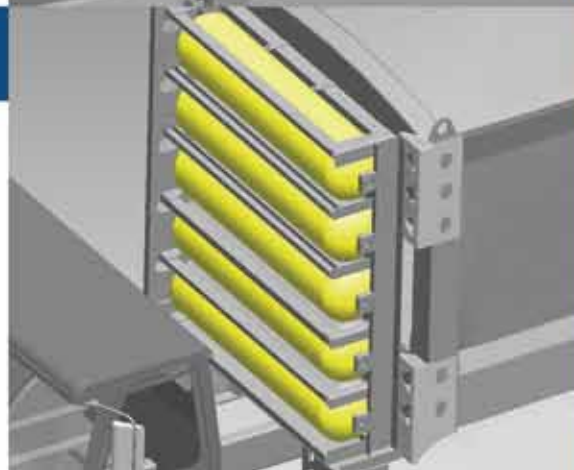

Behind the Cab

(Heil STARR® System)

Specifically available for Heil's STARR® System, a semi-trailer automated side loader, this design is similar to the Front of Body design except that the tanks are mounted to the chassis frame rails, directly behind the cab, to enable operation of the chassis when the trailer/body is not attached.

